

# GEMTECH OASIS

## USER MANUAL

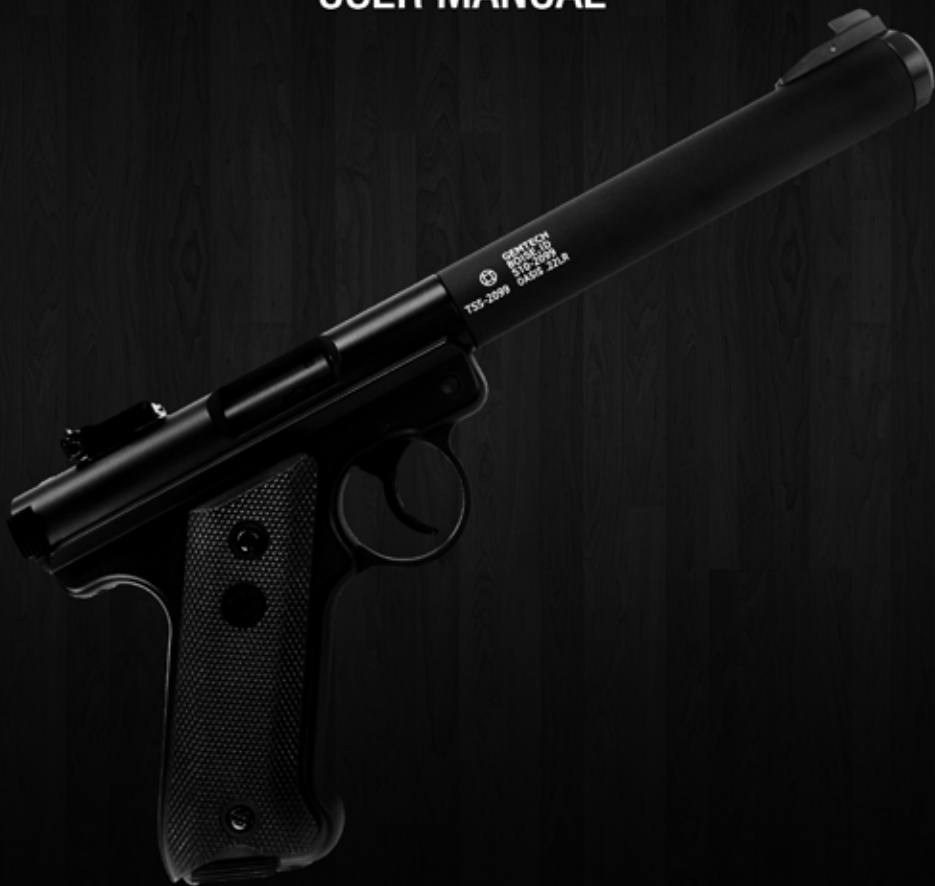

**18**  
"For ages 18 and older"  
"Read operators manual before use"  
"Please leave your questions or comments at [www.socomgear.com](http://www.socomgear.com)"  
"email: [info@socomgear.com](mailto:info@socomgear.com)"

#### DISCLAIMER

Don't change, obscure, alter, remove, or obliterate any correction or markings on this gun. The correction and/or marking on this product, including the price orange, shall be as designed to comply with applicable state and federal law and regulations.

This product may be mistaken for a firearm by law enforcement officers or others. Any person who changes, alters, removes, or obliterate any correction or marking that are required by state or federal law or regulation, in any way that makes this product look more like a firearm is guilty of a misdemeanor.

#### DISCLAIMER

The owner disclaims, transferring and/or exposing of this product in any "public areas" may cause confusion and may be a crime. The term "public areas" means any area owned or rented, including but not limited to, streets, sidewalks, bridges, air/rail, plazas, parks, driveways, front yards, parking lots, automobiles, whether moving or not, and buildings owned by the general public, including those that serve food or drink, or provide entertainment, and the doorways and entrances to buildings or buildings.

Every person who, except in self-defense, shows or exhibits this product in a threatening manner against another in such a way as to cause a reasonable person apprehension or fear of bodily harm is guilty of a misdemeanor punishable by imprisonment in the county jail for a term of not less than 30 days.

## Warning:

### **You have to read manual and agree and understand all terms, conditions, warnings before you operate Airsoft guns**

Everyone wear goggles when you operate Airsoft guns. Don't peek at the muzzle.

Put the toy gun beyond the reach of kids. Don't touch the trigger until the moment of shooting.

Don't aim at people even if it is unloaded. Avoid a rough operation.

When the gun is not in use, remove the magazine and unload the BB. Remember, there might be one BB in the chamber. Use a rod to push it out.

**WARNING:** Don't change, obscure, alter, remove, or obliterate any coloration or markings on this gun. The coloration and/or marking on this product, including the blaze orange barrel tip are designed to comply with applicable state and federal law and regulations.

**WARNING:** This product may be mistaken for a firearm by law enforcement officers or others. Any person who changes, alters, removes, or obliterate any coloration or markings that are required by state or federal law or regulation, in any way that makes this product look more like a firearm is guilty of a misdemeanor.

**WARNING:** The open display, brandishing and/or exposing of this product in any "public place" may cause confusion and may be a crime. The term "public place" means any area opened to public, including but not limited to, streets, sidewalks, bridges, alleys, plazas, parks, driveways, front yards, parking lots, automobiles whether moving or not, and buildings opened to the general public including those that serve food or during, or provide entertainment, and the doorways and entrances to buildings or dwellings.

**WARNING:** Every person who, except in self-defense, draws or exhibits this product in a threatening manner against another in such a way as to cause a reasonable person apprehension or fear of bodily harm is guilty of a misdemeanor punishable by imprisonment in the county jail for a term of not less than 30 days.

**WARNING: Assumption of Risks** There is a serious risk of personal injury, death, or property damage arising out of the use or misuse of this product. By using this product, you agree to freely accept and full assume all such risks.

**WARNING: Exclusion of Liability** In consideration of SOCOM GEAR / MAX Tactical corp granting you the limited warranty set out hereinbelow, neither SOCOM GEAR/ MAX Tactical corp, nor its officers, directors, employees, agents, successors, distributors and dealers (all of whom are hereinaster collectively referred to as the "releasees"), shall be liable for any loss or damage whatsoever, whether general, direct, indirect, special, incidental, consequential, punitive, aggravated or exemplary and whether resulting from ordinary or gross negligence, breach of contract, or breach of any statutory, regulatory or common law duty, and whether such loss or damage is caused to or by this product or by any other product due to any incompatibilities between them or by defects or malfunctions in connection with the use of this product (even if the releasees are advised of the possibility of such loss).

**WARNING: Indemnification** In consideration of SOCOM GEAR / MAX Tactical corp granting you the limited warranty set out hereinbelow, you agree to indemnify the releasees of any liability, damages, legal costs, fees, disbursements, expenses, or any other costs whatsoever, arising out of any claims, suits, or actions brought by a third party against the releasees or any of them in which the third party claims to have suffered any loss or damage that was caused by, contributed to, or related in any way to the use or misuse of this product.

**WARNING: Limited Warranty** SOCOM GEAR / MAX Tactical corp warrants that this product is constructed using plastic, steel and Aluminum. This product is provided without another warranty of any kind, either statutory, expressed or implied, including but not limited to, the implied warranties or implied, including but not limited to, the implied warranties of merchantability, fitness for a particular purpose, title, non-infringement, or arising from a course of dealing, the releasees make no warranties or representations of any kind as to the fitness of this product for any particular purpose.

**WARNING: Choice of Law** The laws of the province of Taiwan and the laws of Republic of China applicable therein shall govern as to the interpretation, validity and effect of this agreement notwithstanding any conflict of laws provisions of your domicile, residence or physical location. You consent and submit to the exclusive jurisdiction of the courts of the Province of Taiwan in any action or processing instituted under or related to this agreement, or to the alleged breach of contract, negligence, gross negligence, or breach of statutory or common law duty of the Releasees.

## ● NAME OF PARTS

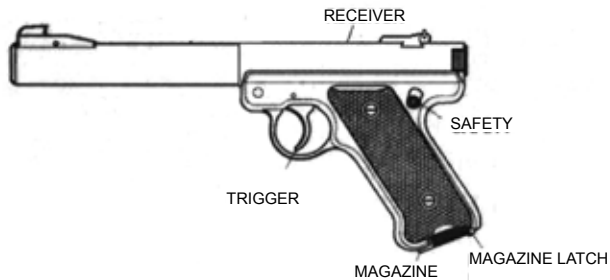

## ● SAFETY



TRIGGER

Do not fire pistol when safety is in 'SAFE' position.

Firing pistol when safety is engaged may result in internal damage.

## ● FILLING GAS

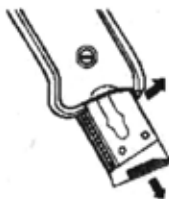

Remove the magazine.

## ● LOADING BBs

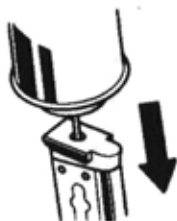

Place magazine upside down.

Insert gas canister into magazine straight down in vertical position.

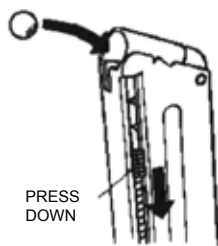

Press the follower down to load BBs.

\*Do not load more than 17 BBs.

## ● FIRING



Install the magazine.  
Check to see if magazine latch produces a "click" sound and closes tightly.  
Do not fire pistol without magazine, as this may cause internal damage.



Begin firing.

Firing continuously for an extended period may cause the temperature and gas pressure within the magazine to lower, decreasing performance. Normal operation should resume after a short rest.

## ● TRAJECTORY ADJUSTING

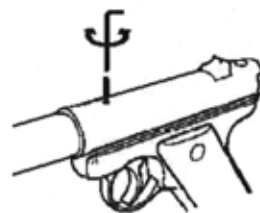

Use hex key to adjust trajectory.  
\*Overly tightening the screw may result in BBs becoming stuck inside the chamber.

DESIRED RESULT	ACTION
Moves upward.	Loosen screw.
Farthest shooting range.	ACTION
Naturally falls down.	Tighten screw.

## ● DISASSEMBLY

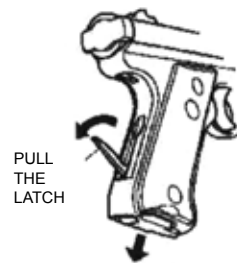

Remove the magazine and pull the latch lever out toward the rear.

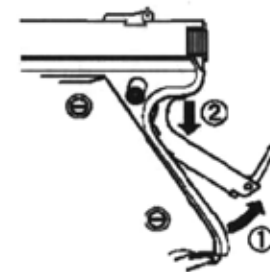

1. Swing the mainspring housing out and turn it toward the rear.
2. Pull the housing straight down to the bolt-stop pin from the frame and barrel extension.



Move the barrel/receiver assembly forward to free it from the internal hook at the front of the frame.

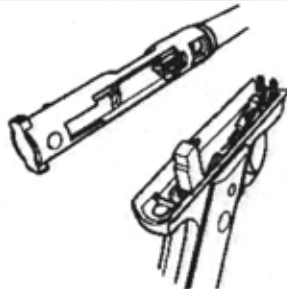

Gun is now fieldstripped.

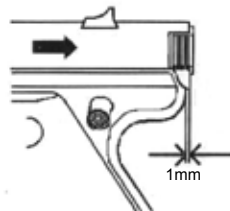

Push the barrel/receiver back about 1mm

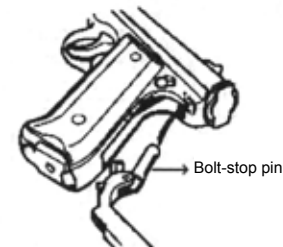

Place the mainspring bolt-stop pin into the base of the receiver and through its hole in the barrel.

## ● REASSEMBLY

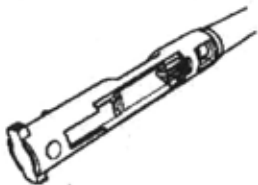

Ensure all parts are in the correct position.

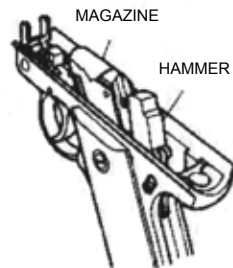

Release the gas, install the magazine, and place the hammer forward.

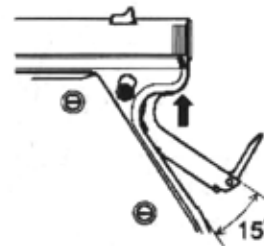

Swing the mainspring housing.

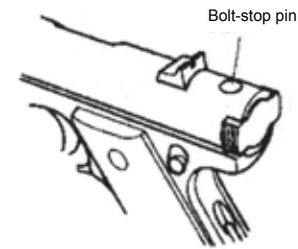

Ensure the bolt-stop pin is secure.

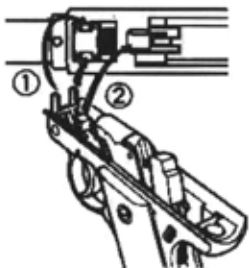

Place the barrel/receiver assembly on the frame.

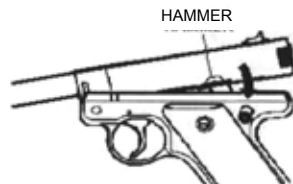

Ensure hammer is in forward position.

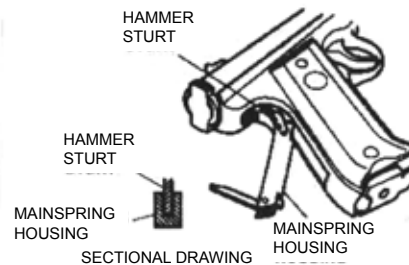

With the sturt in place, latch the mainspring unit shut and lock the housing latch.

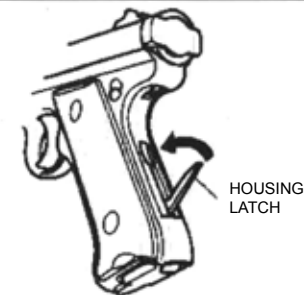

Lock the housing latch.

# EXPLODED VIEW

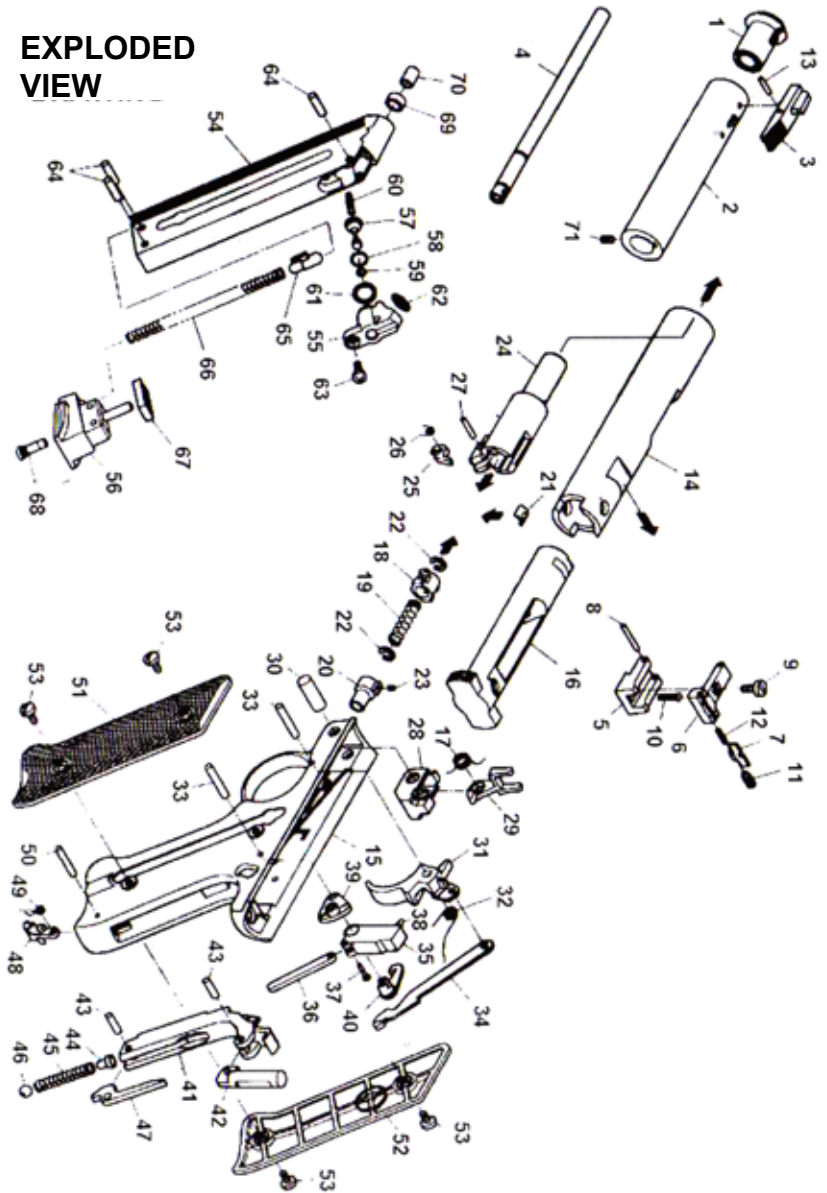



18

GREEN  
GAS

ISGK  
.org

"For ages 18 and older"  
"Read operators manual before use"  
"Please leave your questions or comments  
at [www.socomgear.com/](http://www.socomgear.com/)  
"email: [info@socomgear.com](mailto:info@socomgear.com)"

**DISCLAIMER:**

Don't change, obscure, alter, remove, or obliterate any  
corrosion or markings on this gun. The corrosion and  
or marking on this product, including the color orange  
barrel is designed to comply with applicable state  
and federal law and regulations.

This product may be misused by a firearm by law  
enforcement officers or others. Any person who changes,  
obscure, removes, or obliterate any corrosion or marking  
that are required by state or federal law or regulation,  
in any way that makes this product look more like a  
firearm is guilty of a misdemeanor.

**DISCLAIMER:**

This cover, slides, branding and/or markings of this product in any "public place"  
may cause confusion and may be a crime. The term "public place" means any area  
open to public, including but not limited to, stores, schools, hotels, airports,  
parks, party, drivers, front yards, parking lots, automobiles, whether moving or  
not, and buildings owned by the general public, including those that serve food or  
drinks, or provide entertainment, and the doorways and entrances to buildings or  
facilities.

Every person who, except in self-defense, drives or exhibits this product in a  
threatening manner against another in such a way as to cause a reasonable person  
apprehension or fear is guilty of a misdemeanor, provided by  
agreement in the county jail for a term of not less than 30 days.